



INSTALLATION & INSTRUCTION  
MANUAL  
for  
GREEN HEAT PUMP



[www.greenheatpump.com](http://www.greenheatpump.com)

# Contents

0. Introduction	3
0.1 COP Graph	4
1. Installation and Connection	5
1.1 Unit Location on Site	5
1.2 Connection	6
1.3 Connecting the SPLIT Units	8
2. First Starting up	12
3. Setting and Operation	13
4. Maintenance	17
4.1 To be checked up regularly	17
4.2 Leakage	17
4.3 Winterizing	17
5. Error Indications and Trouble Shooting	19
6. Wire Connection Tables	21
7. Units specifications	26



Other views:



## 0. Introduction

Thank you for buying the Green Heat Pump. Please read this manual, and take the advantages of the benefits of this unit.

Learn how to read all the information on the display. You can easily optimize the Heat Pump performance.

### General information

The heat exchanger of the Heat Pump is made from PVC & titanium tube which withstands prolonged exposure to corrosives such as chlorinated water or brine.

The swimming pool Heat Pump is easy to connect to the filter system (see chart on p. 5) The water pressure drop is less than 0.1 bar (10 kPa) at the normal flow rate. The flow switch (see p. 9) will stop the unit if the flow is insufficient. PVC pipes can be run straight into the unit.

### Function and Connection Chart of the Heat Pump

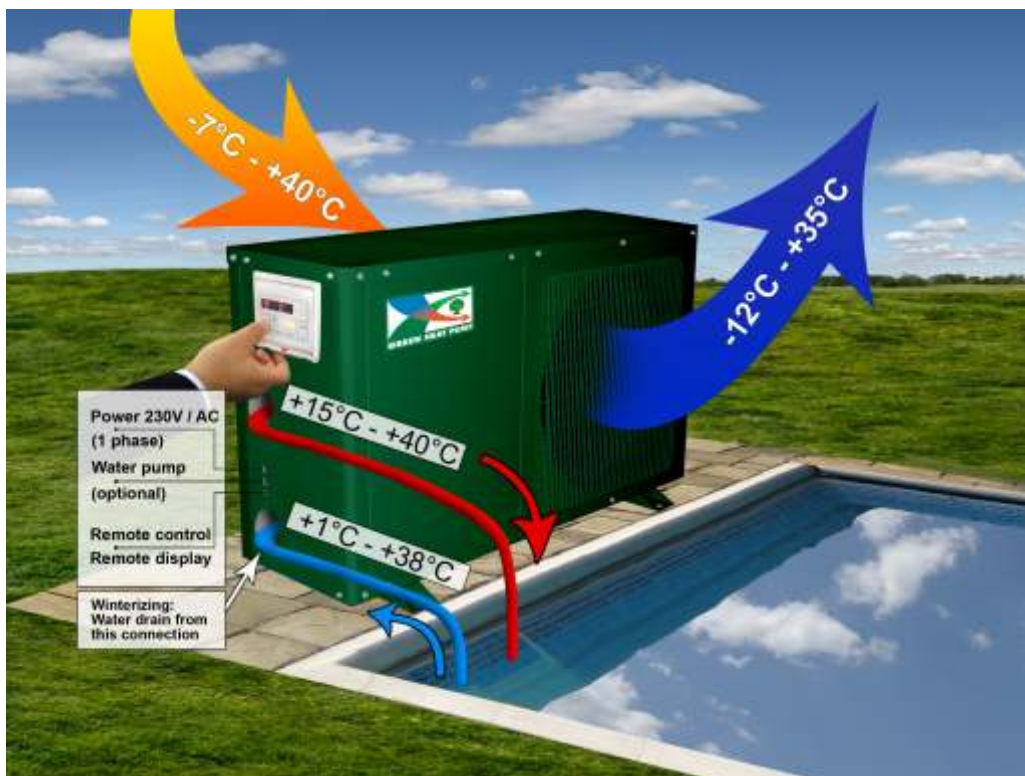

How the Green Heat Pumps are designated:

PG15C-410-(3)

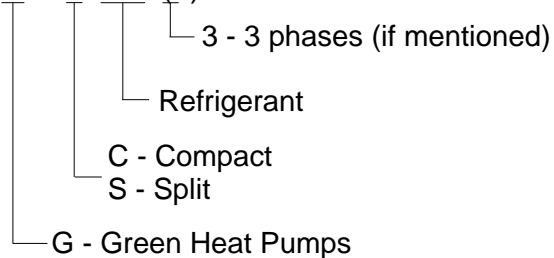

Producer:  
Green Heat Pumps  
Limassol  
Cyprus

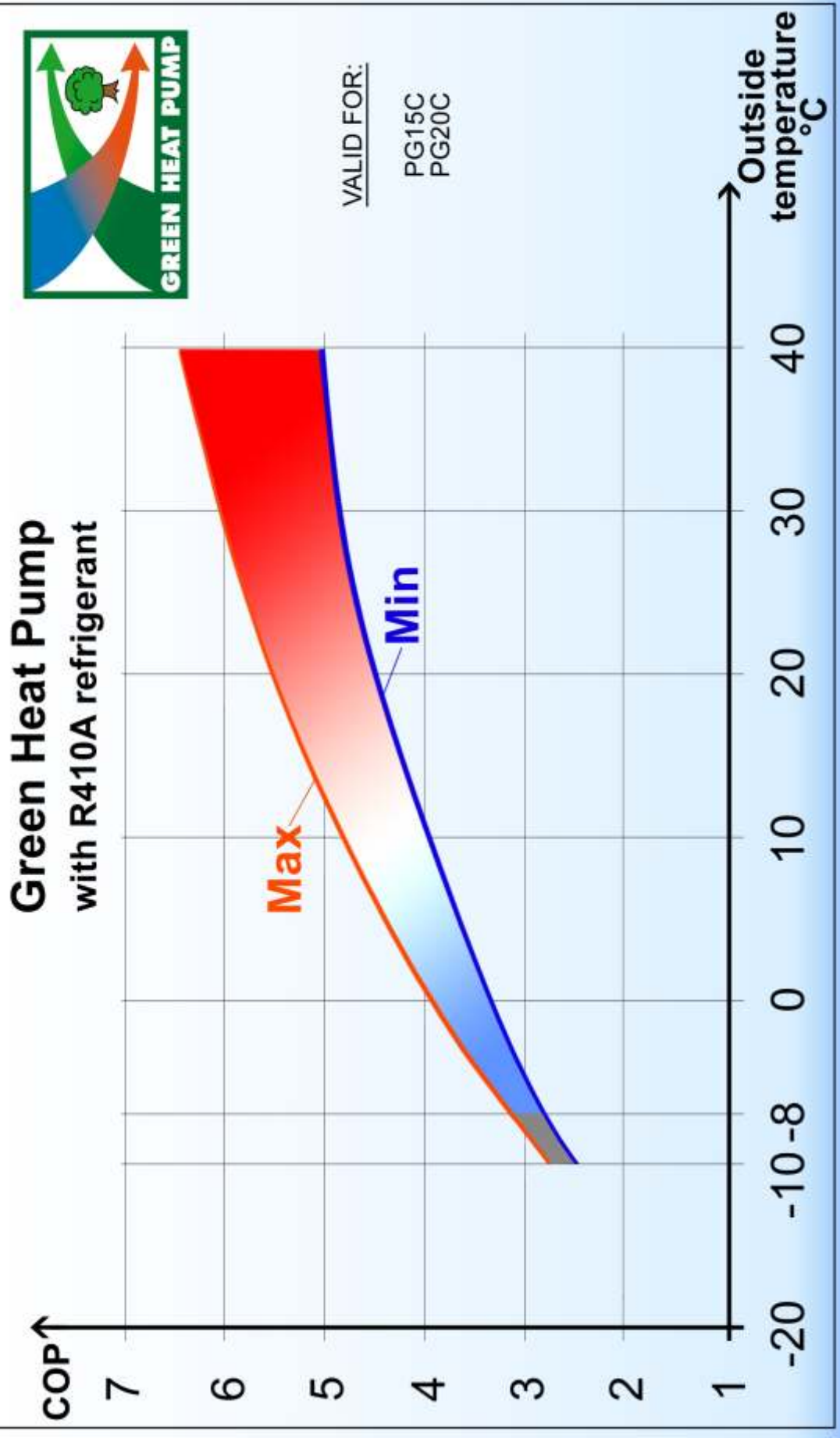

# 1. Installation and Connection

## 1.1 Unit Location on Site

1. This unit should be installed outdoors, under special conditions also indoors.
2. Connect the unit to the pool pump pressure side after all filters and before any chlorinators, ozonators or dosing equipments (see next page). Place the heat pump unit as close to the filter system as possible. It should be less than 15 m (50 feet).
3. The standard model will accept 50 mm (11") PVC pipe for connecting to the pool filtration piping.
4. Consider the positioning of the water inlet and outlet to have good access for easy draining of the unit for the winterizing.
5. The noise level is low, nevertheless we recommend to place the unit far away from the sitting area so that you can enjoy your pool in silence.
6. Observe the distances from a wall or other objects as given in the picture below, so that the air can flow unrestricted (bushes or other objects around).
7. The heat insulation of the water tubes between the unit and the filter system is very important for energy saving.  
For example: In case of 10 m distance and 10 deg C temperature difference between the pool water and the ambient air, 2 cm insulation is required; the heat loss will be approximately 0.5 kW. The Heat Pump will run c. 2-4 % longer. Without the insulation the heat loss will be ca 1.5 kW, the unit will run 6-10 % longer.
8. The heating process generates condense water. Water drips into the base-pan and can be led away with a hose. Under special weather conditions the process can produce several litres within a short time. That is normal. If you suspect leakage, follow the instructions on the page 15.

**Important: Min. distance to obstacle or walls**

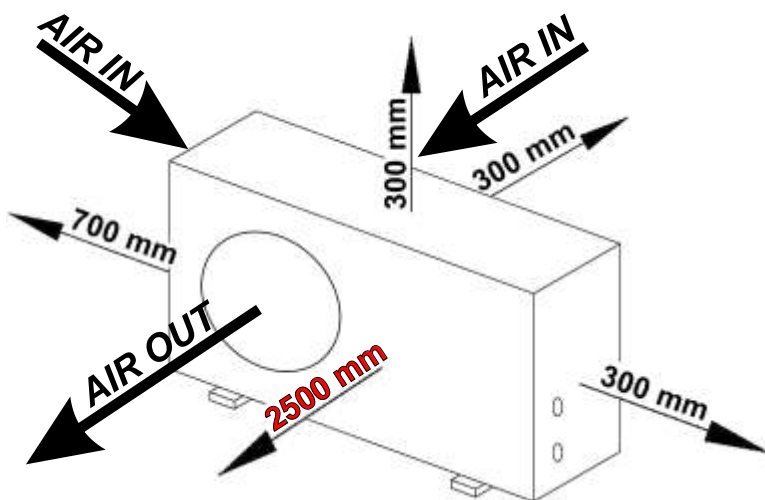

*Air-flow: Horizontal*

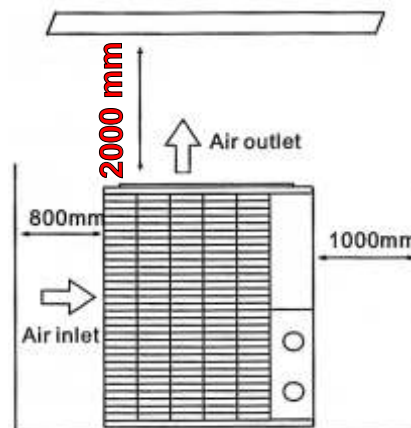

*Air-flow: Vertical  
(Air-flow: Upwards)*

# 1. Installation and Connection

## 1.2 Connection

Water flowing out of filter is divided by three valves: Some water is led to the Heat Pump to be heated/cooled and then after being mixed with the water from the filter it is led back to the pool.

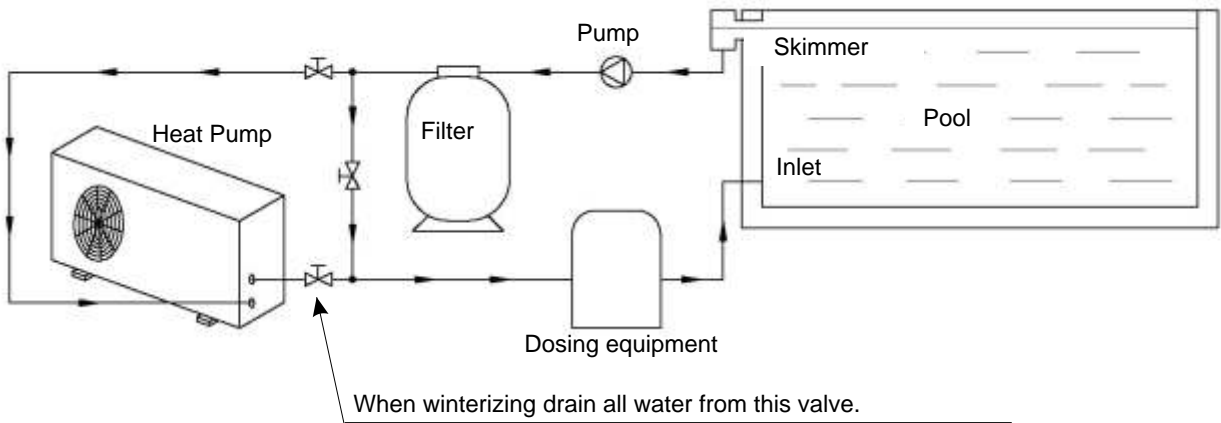

## Tandem Connection

This connection is used for 2 coupled heat pumps.

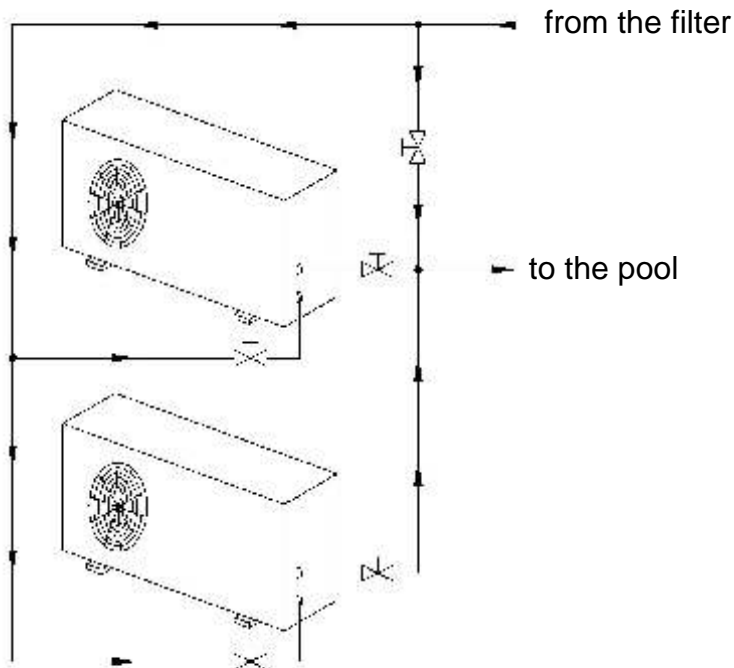

## 1.2 Wrong Location and Connection (Examples)



The unit is located too close to the wall.



Wrong connection of the valves

Separate valves for IN-going and OUT-going water are necessary (see p. 5).

## 1.3 Installation and Connection - Split Unit

### 1.3.1 Connection of the two units of the SPLIT Heat Pump

#### Description and Location

The Main Unit (the bigger cabinet) has to be located outside (under special conditions also inside - in a room with warm air continuously regenerated with energy, eg. with equipment that continuously warm the air).

The Heat Exchanger (the smaller cabinet) is supposed to be installed in the filter room connected to the water flow from the filter. On the Heat Exchanger there is display/control panel.

The distance between these units should be kept within 10 m (33 ft). The Main Unit must be connected to the Heat Exchanger with 2 pipes for the refrigerant (see the picture below). One pipe is bigger than the other. The bigger (thicker) pipe is transporting the refrigerant gas from the Main Unit to the Heat Exchanger (inside). In the Heat Exchanger the energy is transferred to the pool water, the gas turns into liquid form and is transported by the smaller pipe back to the Main Unit. (The liquid needs smaller pipe than the gas.)

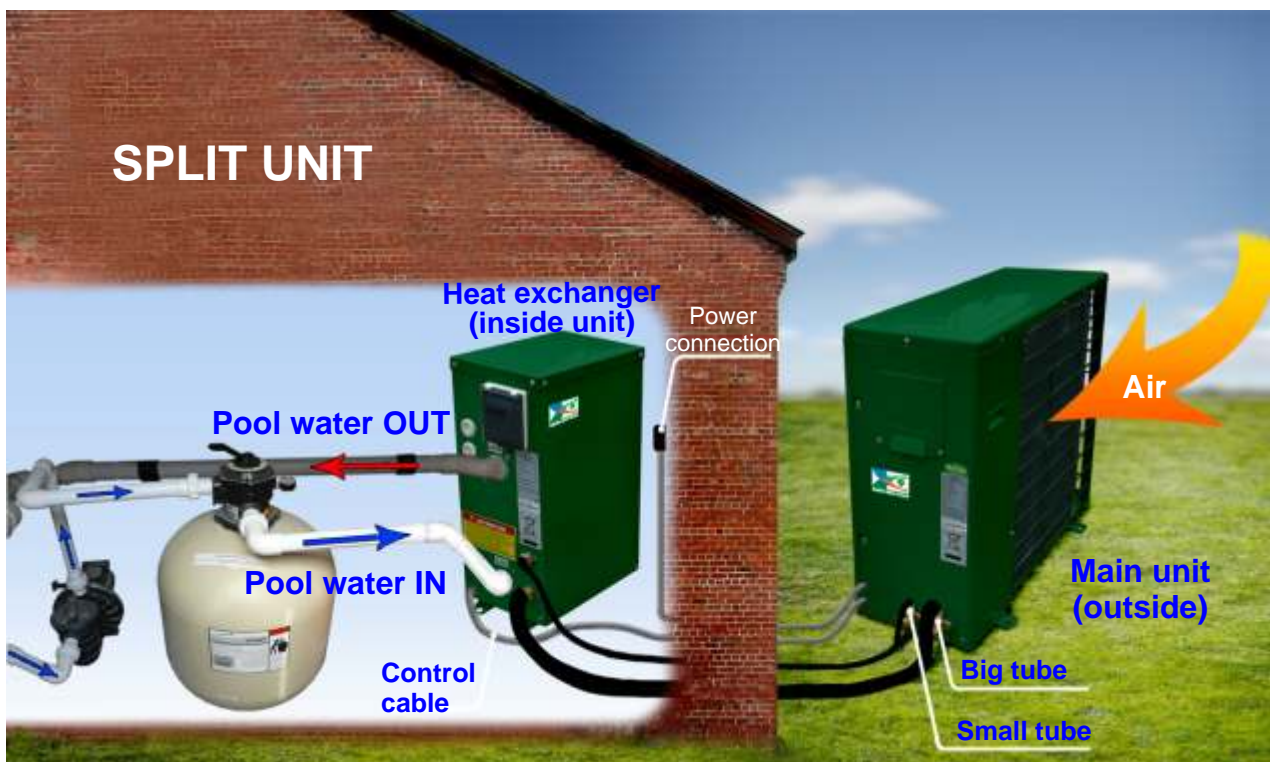



# Split Heat Pump Unit - Connection



Outside Unit

Heat Exchanger - Inside unit (smaller cabinet)



use Hexagonal key 5 mm

## Nuts Measurement

- A - 22
- C - 22
- E - 14
- B - 27
- D - 24
- F - 14
- G - 22
- H - 27



Tube connection

1. Connect thick tube between **B** and **H** and tighten properly
2. Connect thin tube to **G** and tighten properly
3. Connect thin tube loosely on **A**
4. Take off the cap on **D**
5. Open a valve **J** (under the cap C) only a little and feel air coming out on **A**
6. Feel air and gas coming out on **A**
7. After 3 - 5 sec feel gas only coming out on **A** (observe a gas fog)
8. Tighten tube on **A** tight
9. Open valve **J** and **K** fully
10. Check that all connections are fully tighten
11. Put back the caps on **C** and **D** and tight fully

**Units are ready to start**

## Connection before starting

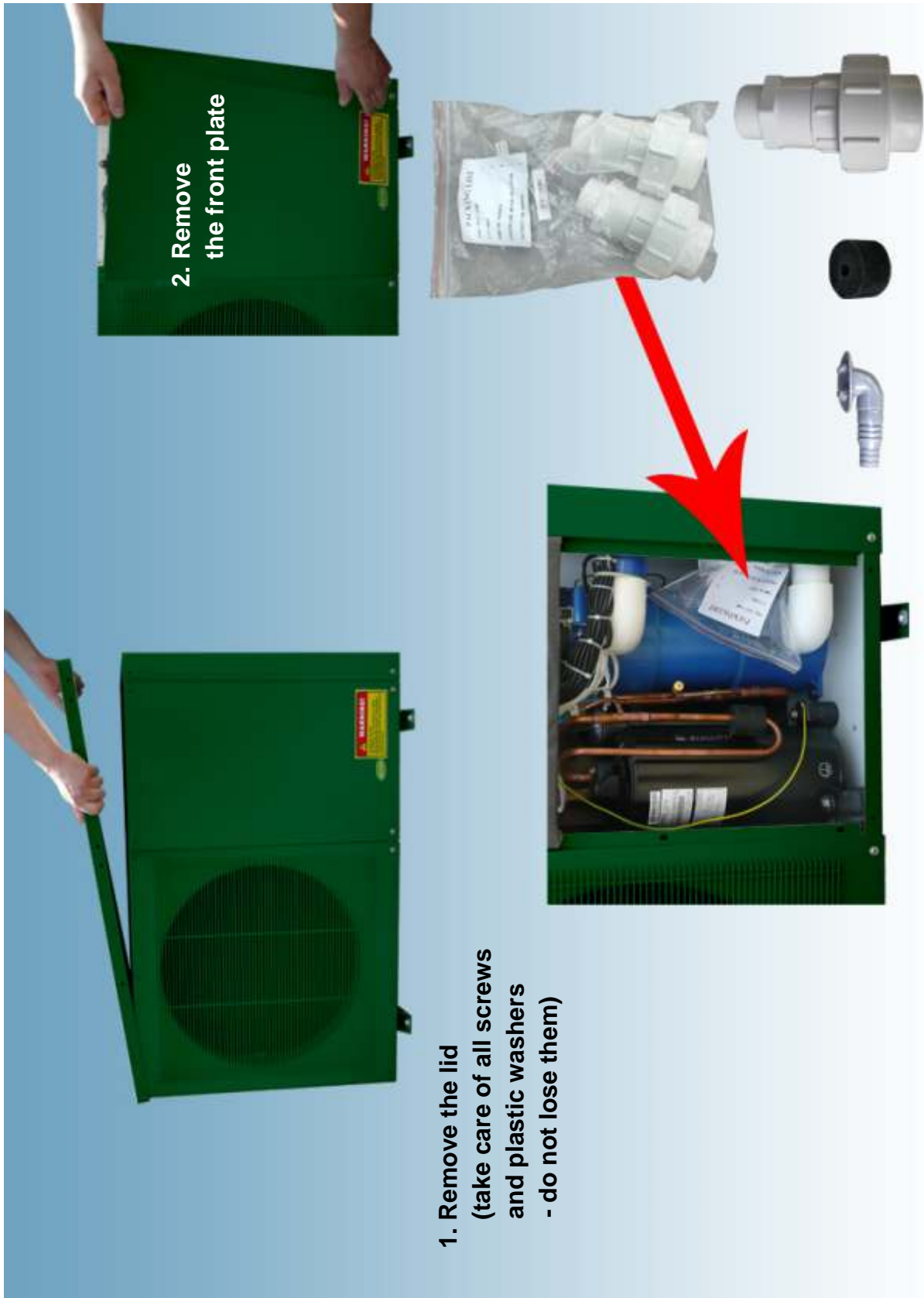

## Connection before starting

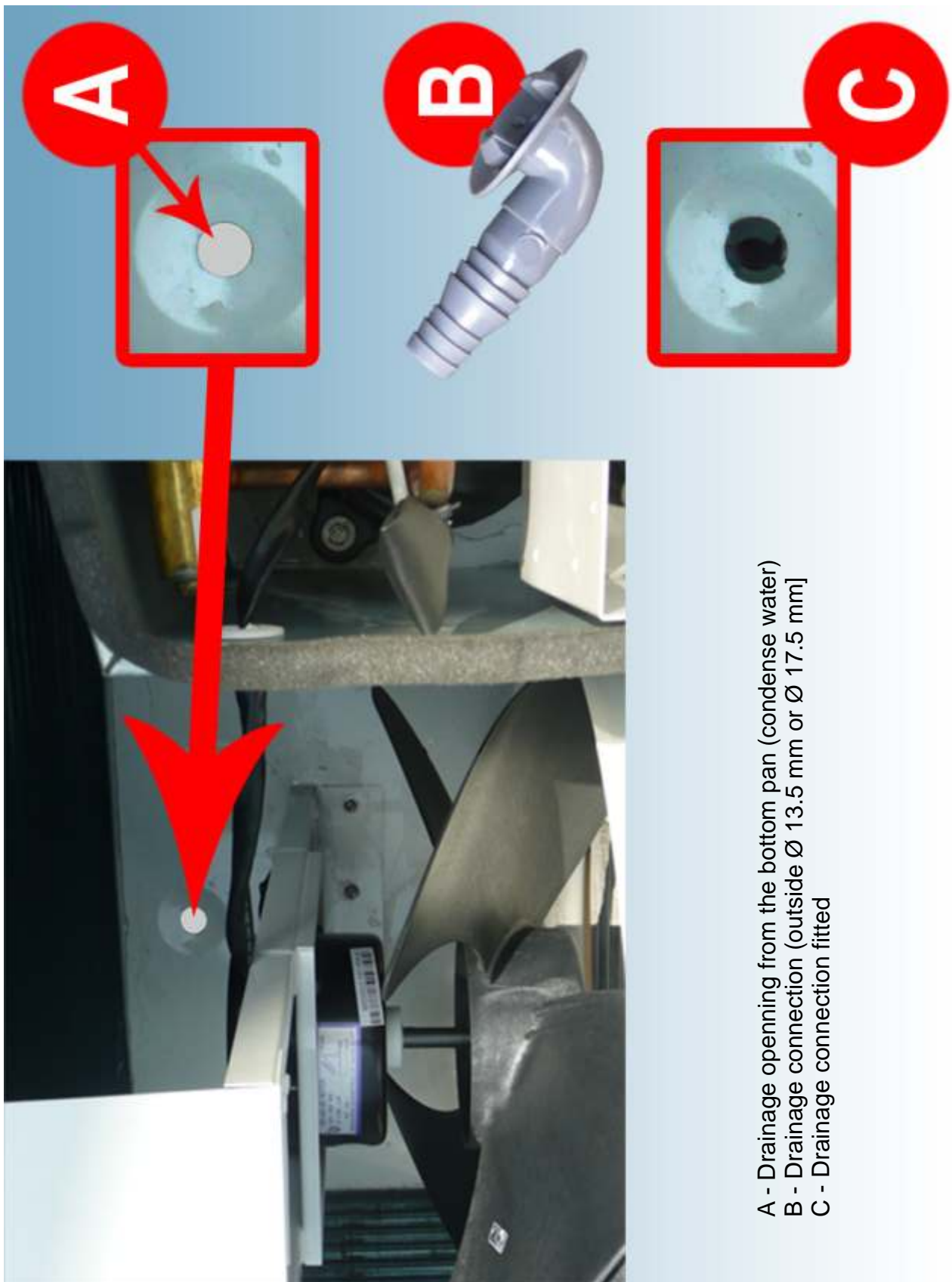

- A - Drainage opening from the bottom pan (condense water)
- B - Drainage connection (outside Ø 13.5 mm or Ø 17.5 mm)
- C - Drainage connection fitted

## 2. First starting up

### 1. Turn the filter pump on. Check the flow

Check the unit for water leakage and verify the flow to and from the pool.

### 2. Turn the unit on

Turn the electrical power supply with the main switch . There is some delay before the fan starts running. Similarly, the compressor starts also after some delay.

When the unit is on and the flow rate is too small, the flow switch will automatically turn the unit off.

### 3. Check the air temperature and the automatic stop (after 10 minutes)

After a few minutes running make sure the air leaving the front side of the unit is cooler than the air coming in (about 10 deg).

When the unit is running, turn the filter pump off. The units should also stop automatically.

### 4. Check the water warming-up (after 24 hours)

Let the unit and the pool pump to run 24 hours per day continuously until the desired pool water temperature is reached. When the set water-in temperature is reached (setting the values see p. 13), the unit stops. It will restart automatically (if the pool pump is running) when the water pool temperature drops more than 2 deg below the set temperature.

## Technical notes

**Flow switch** The unit is equipped with a flow switch that turns it on when the pool pump is running and shuts it off when the pump switches off. If the water flow (see technical Unit Specification) through the Heat Pump is too low the Heat Pump will also shut off.

### **Solid state restart delay**

The unit is equipped with a 3 minute built-in solid state restart delay included to protect the control circuit components and to eliminate restart cycling and contact chatter. This time delay will automatically restart the unit approximately 3 minutes after each control circuit interruption. Even a brief power interruption will activate the solid state 3 minute restart delay and prevent the unit from starting until the 3 minute countdown is completed. Power interruptions during the delay period will have no effect on the 3 minute countdown.



### 3. Setting and Operation

#### 3.1 LED Controller

The settings and operation of the Heat Pump are performed on the LED Controller. The LED screen contains two two-digit numbers. The first number indicates operation parameter, the other gives the value of the parameter.

The parameter value can be viewed while the pump is running by pressing ? or ? . If no button is depressed within 5 seconds, the LED displays the water-in temperature. **When the unit is turned OFF, current time is displayed.**



Setting a parameter value is possible only when the unit is turned off.

By pressing ? or ? the parameter is chosen, and by simultaneous pressing "MODE" and the main switch  (first press "MODE", hold it, and then press the main switch) the value can be changed. **By next** pressing the main switch  the value is set and stored.

Exception: If the parameter 8 is set to 1 (heating or cooling) you can change from heating to cooling by pressing MODE while the Heat Pump is running.

**Viewing the parameters:** Press ? or ? . (see next two pages)

**Changing the parameters:**

1. Switch the Heat Pump OFF by  . (Clock will be displayed.)
2. Choose the parameter by pressing ? or ? .
3. Press and hold MODE and then press  .
4. Release both buttons.
5. Change the parameter by pressing ? or ? .
6. Press  . The new value is stored.

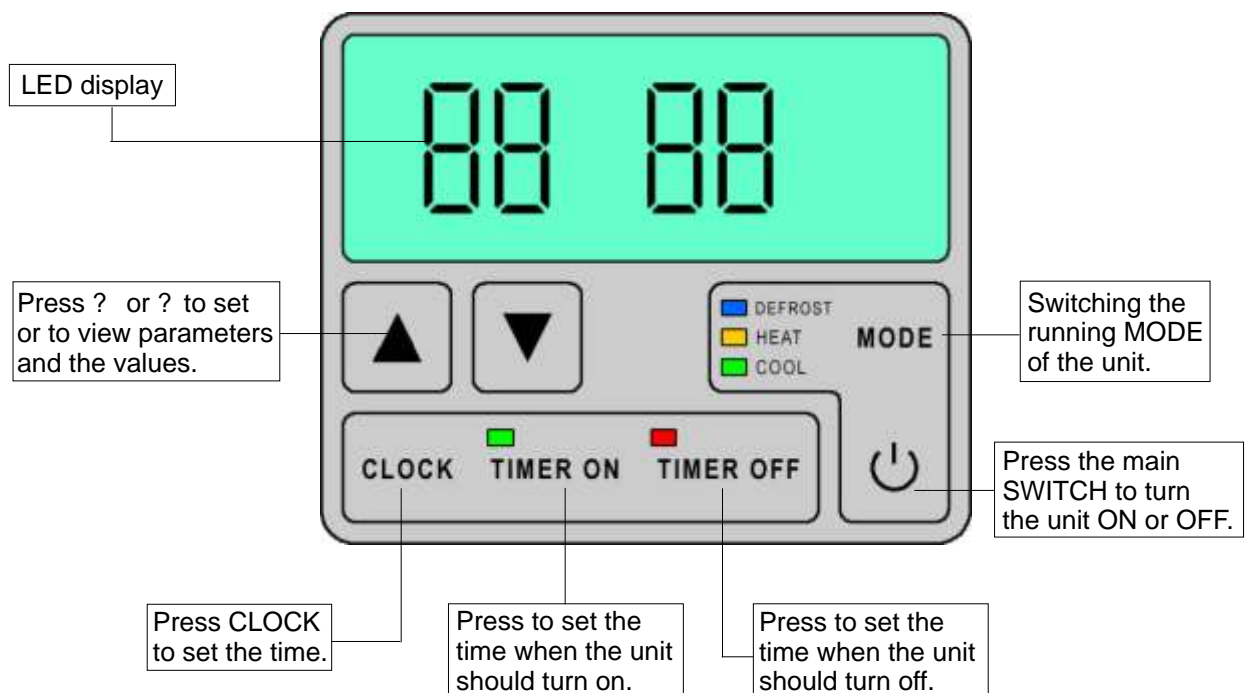

# Settings

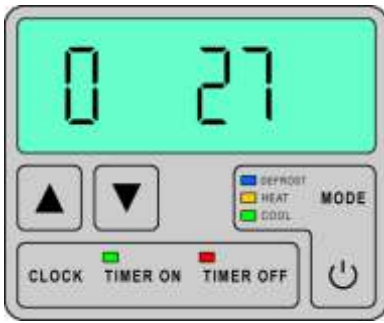

## Cooling

Temperature of the out-going water in cooling mode.

Range: 5 to 35 °C

Default: 27 °C

The heating MODE can be changed to Cooling MODE when the pump is running only by pressing MODE.

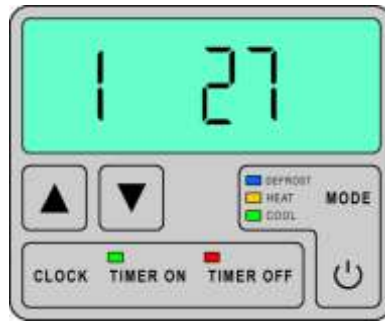

## Heating

Temperature of the out-going water in heating mode.

Range: 5 to 40 °C

Default: 27 °C

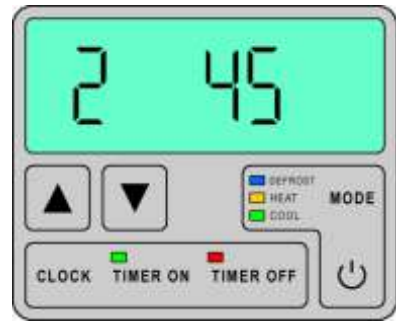

## Defrosting Start (2+3)

Running time of the compressor after getting ice on evaporator (energy collector).

Range: 30-90 min

Default: 45 min

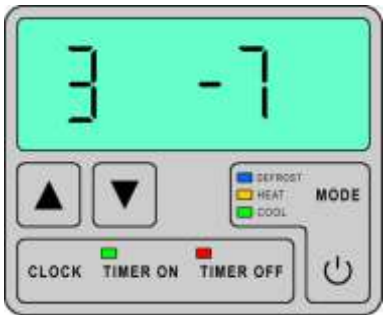

## Defrosting Start (2+3)

Temperature to start the DEFROST function.

Range: -30 to 0 °C

Default: -7 °C

**Note:** Both conditions, i.e. parameters 2 and 3 must be fulfilled to start the DEFROST mode.

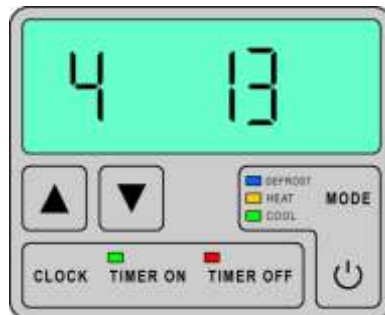

## Defrosting Stop (4+5)

Temperature to turn the DEFROST function off.

Range: 0 to + 30 °C

Default: 13 °C

**Note:** One of the conditions, i.e. either parameter 4 or 5 is enough to stop the DEFROST mode.

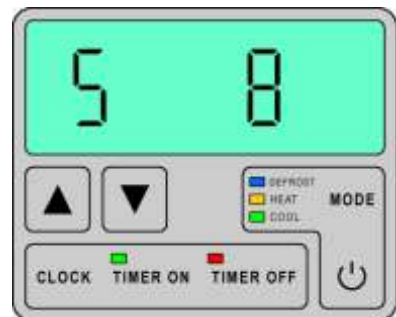

## Defrosting Stop (4+5)

Maximum defrosting time.

Range: 1 to 12 min

Default: 8 min

**Note:** If the unit is in the defrosting mode, the blue DEFROST light on the controller is on.

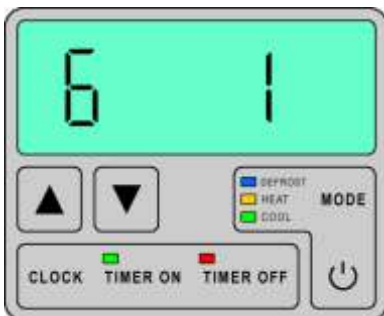

## Electric-valve adjust (if installed)

0 - manual

1 - automatic

Default - 1

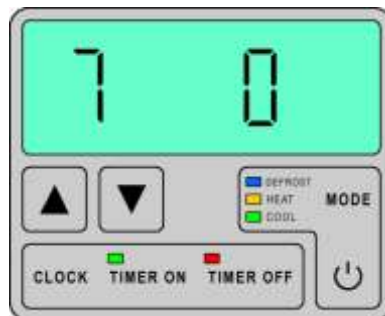

## Auto restart

Automatic restart after power failure.

0 - no auto restart Heat Pump remains off.

1 - automatic restart of the Heat Pump after power failure

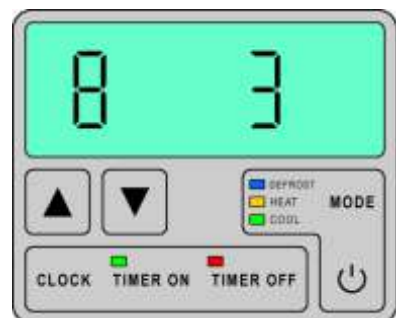

## Running mode

0 - cooling only

1 - cooling & heating

2 - not available

3 - heating only

**Note:** Switch the mode by pressing the MODE button. This is possible only if "8" is set to "1". All other settings can be changed only when the pump is turned off.

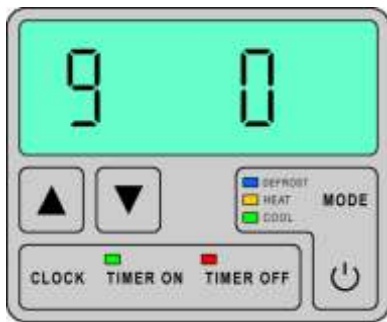

**Pump**

0 - always running (e.g. because of filtering...)  
 1 - The pump starts 60 seconds before the compressor starts, and stops 30 seconds after the compressor stops.

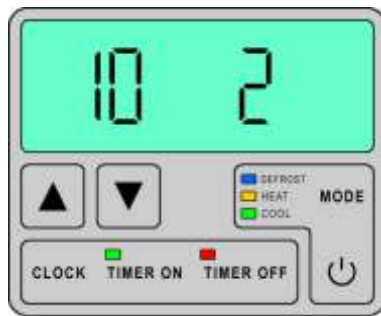

**Fan mode selection**

0 - low fan speed  
 1 - high fan speed  
 2 - automatic fan speed (high speed when air temperature is below 10°C, low speed when air temp. is above 15°C) Hystiress 5°C  
 3 - low fan speed during 9 PM to 8AM, high speed at other time  
 4 - automatic running according to above condition 2 and 3

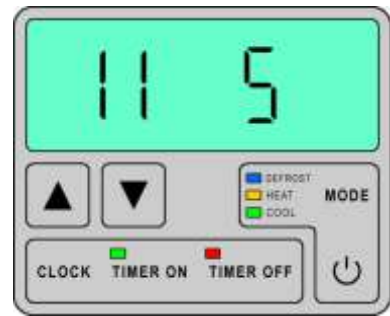

**El. valve overheat control**

Range: -20 - +20°C  
 Default: 5°C

**Current Status**

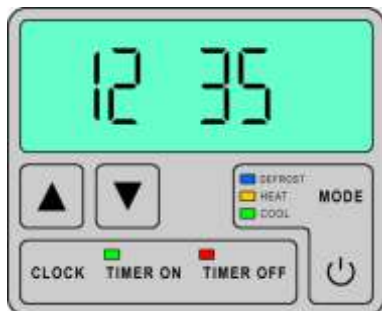

**El. valve start set (slow s.)**

Range: 0 - 50  
 Default: 35

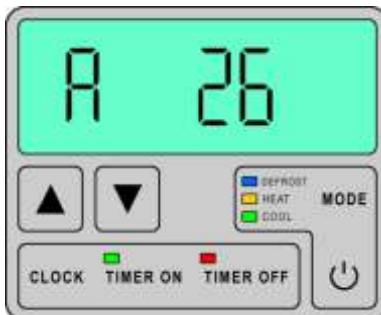

Current temperature of the in-coming water from the pool.

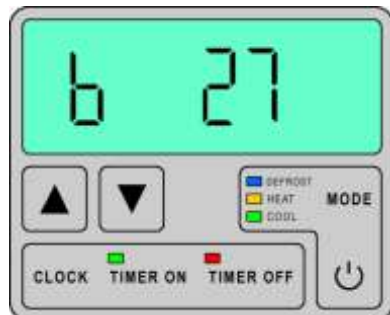

Current temperature of the out-going water to the pool.

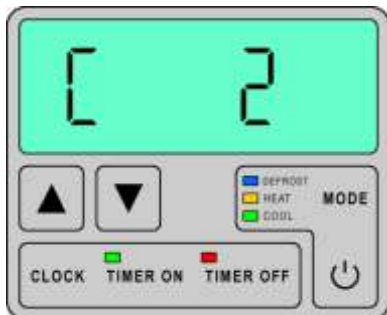

Temperature on the Evaporator 1

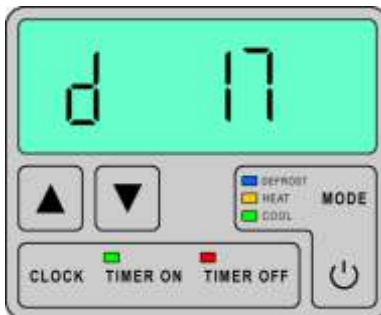

Temperature on the Evaporator 2  
**Note:** If the evaporator is not installed then 17 is displayed.

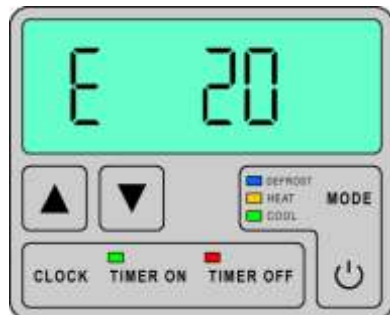

Ambient air temperature

## Setting TIME & TIMER

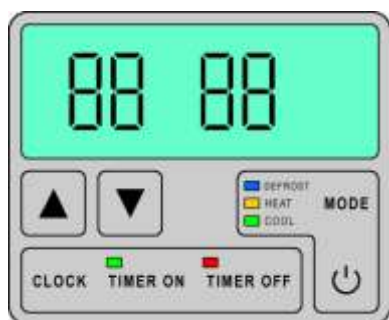

### Setting time

1. Switch the unit OFF.
2. Press CLOCK.
3. Press ? /? to set hour.
4. Press CLOCK.
5. Press ? /? to set minutes.
6. Press CLOCK to store.

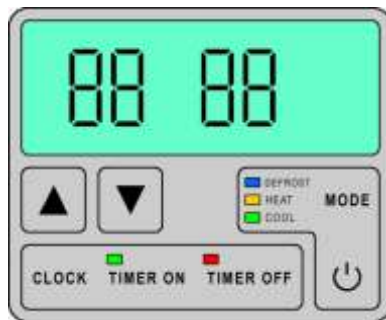

### Setting Time for TIMER ON/OFF

The timer is set by pressing TIMER ON (or TIMER OFF) and subsequent setting the time by ? /? . By pressing CLOCK the timer time is stored.

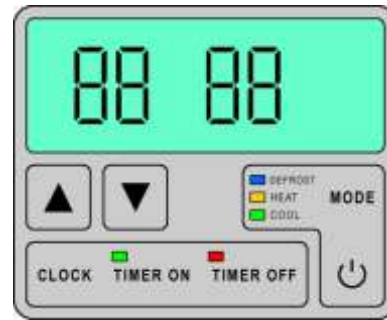

### Cancelling the TIMER

The timer settings can be cancelled by pressing CLOCK, while the pump is ON.

<u>Program</u>	<u>Range</u>	<u>Default</u>
0. Water Temp. Cooling Mode	35 - 5 °C	27
1. Water Temp. Heating Mode	5 - 40 °C	27
2. Min. Time between Defrost	20 - 90 Min	45 Min
3. Defrosting Start temp.	-30 - 0 °C	-7
4. Defrost Stop Temp. (Heating)	0 - 30 °C	13 °C
5. Defrost Time (Heating Mode)	1 - 12 Min	8 Min
6. Electric Valve Man./Auto	0 / 1	1
7. Auto restart after Power Out	0=N - 1=Y	1
8. Mode: Cool only/Cool&Heat/ aux El. Heating/Heat only	0/1 2/3	3 3
9. Filter Pump Control: On/Delay	0/1	1
10. Fan Speed & Mode	0/1/2/3/4	2
11. El. Valve Overheat Control	-20 - +20°C	5°C
12. El. Valve Start Set (Slow S.)	0 - 50	35
A. In-coming Water Temp.	Display only	
B. Out-going Water Temp.	Display only	
C. Temp. on Evaporator 1	Display only	
D. Temp. on Evaporator 2 (if)	Display only	
E. Ambient Air Temp.	Display only	



## 4. Maintenance

### 4.1 To be checked up regularly

#### **Water supply and water flow**

Lack of water or air entering into the system influences the performance and reliability of the unit. The pool filter should be cleaned regularly.

#### **Surroundings of the unit**

Keep the area around the unit dry, clean and well ventilated. Clean the evaporator area (energy collector) regularly to maintain good COP (efficiency) and save energy.

**Cleaning:** Shut the electrical supply. Clean the evaporator with warm water (if possible, but not under high pressure). Be careful not to damage the collector fins. Do not open the cabinet.

### 4.2. Leakage

#### **Condense water basics**

Since the Heat Pump cools down the air about 10 degrees, water may condense on the fins of the evaporator. If the relative humidity is very high this could be as much as several litres an hour. The water will run down the fins into the base pan and drain out through the plastic drain fitting. This fitting is designed to accept 3/4" PVC tubing which can be pushed on by hand and run into a suitable drain. It is easy to mistake the condensation for a leakage inside the unit.

#### **Distinguishing condensation and pool water inside the heat pump**

A quick way to verify that the water is condensation, and not a leakage, is to shut off the unit and keep the pool pump running. If the water stops running out of the base pan, it is condensation water.

Even quicker way is to test the drain water for chlorine with the pool tester, if there is no chlorine present, then it is condensation (in case that the pool is sanitized with chlorine).

The operation pressure of the refrigerant system should be serviced only by a certified technician, preferably by a Green Heat Pumps workshop.

### 4.3 IMPORTANT: Winterizing

#### **Prevent freezing: All water must be discharged from the unit before winter**

Before the Heat Pump is shut down for the winter period, all water in the pump and water system must be drained (discharged) to prevent freezing. Water is drained from the lower water connection (water inlet to the unit). Before first starting the Heat Pump after a longer period the system must be fully filled with water.

## Maintenance

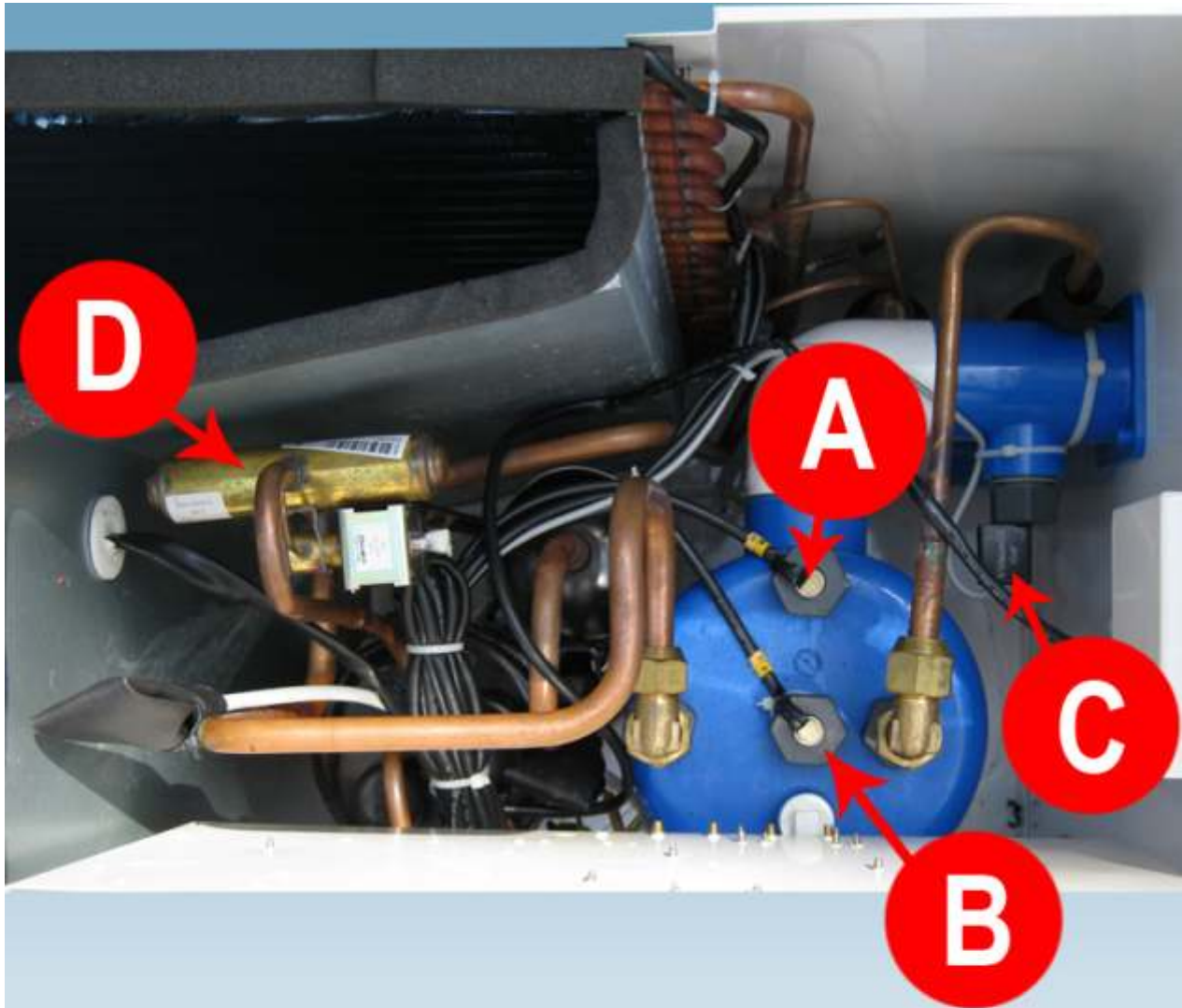

- A - Out-going water temperature sensor
- B - In-going water temperature sensor
- C - Water flow sensor
- D - Multifunction refrigerant valve

## 5.1 Error Indications and Trouble Shooting

In case of any trouble the code is displayed on the LED controller.

Malfunction	LED Controller	Reason	Solution
Water inlet temperature sensor failure	PP1	The sensor is open or short circuit	Check or change the sensor.
Water outlet temperature sensor failure	PP2	The sensor is open or short circuit	Check or change the sensor.
Coil 1 sensor 1 failure	PP3	The sensor is open or short circuit	Check or change the sensor.
Coil 2 sensor 2 failure	PP4	The sensor is open or short circuit	Check or change the sensor.
Ambient air sensor failure	PP5	The sensor is open or short circuit	Check or change the sensor.
Temperature difference between water-in and water-out is too large	PP6	Water flow volume not sufficient, water pressure too low.	Check the water flow switch. Check the water flow volume, or system obstruction.
The first time freezing protection in winter	PP7	Ambient or inlet water temperature is too low.	No action
The second time freezing protection in winter	PP7	Ambient or inlet water temperature is too low.	No action
Anti-freezing under cooling mode	Pp7	Outlet water temperature is too low.	Check the water flow volume or outlet water temp. sensor.
Malfunction of system 1 or 2  (Only 3 phase units)	EE1 EE2	System 1(or 2) protection has failed.	Check each protection point of the system 1(2), remove the malfunction according to System Protection Board Malfunction Table. Only for 3-phase engines.
Flow switch failure	EE3	No or too little water flow, freezing, switch failure	Check the flow/ pump functioning Check/change the switch.
Wrong power supply connection	EE4	Wrong connections or no connection	Check the connection of the power cable.
Wrong power supply connections (PG25C)	nothing displayed		
High/low pressure (PG10C/PG15C/PG25C)	EE4	Refrigerant charge too low or high. Possible system blockage.	Check through each pressure switch and return circuit.
The water-in and water-out temp. difference too high. Error is displayed after this occurs for 3 times within 30 minutes.	EE5	Water flow rate not sufficient.	Check the water flow rate or whether the system is jammed.
Communication failure	EE8	LED controller and PCB connection failure	Check the wire connection or change LED controller or PCB.

## 5.2. System Protection Board Malfunction Table

(Applicable only 3 phase units)

Disp. code	Problem description	Reason	Action	Recovery	Resolution
1	Icing/freezing on evaporator at the refrigerant inlet	Refrigerant temperature from the tube outlet is too low	Unit stops, alarm	Y	Reduce the amount of the refrigerant
2	Refrigerant leakage	Refrigerant temp. Before tube inlet is too low.	Unit stops, alarm	Y	Increase the amount of the refrigerant
3	Low pressure	Low pressure switch action	Unit stops, alarm	Y	Check the pressure switch and turn the heat pump on
4	Compressor output temp. too high	Compressor exhaust temperature is too high.	Unit stops, alarm	Y	Check the refrigerant system
5	Over-current on compressor	Current through the compressor is too high	Unit stops, alarm	Y	Check voltage on the power supply, check short circuit at compr.
6	High pressure	High pressure switch action	Unit stops, alarm	Y	Check the pressure switch (replace switch) and turn the heat pump on
7	Failure of the temperature sensor before tube*	Temperature sensor opened or short circuit	Unit stops, alarm	Y	Check the sensor (replace sensor)
8	Failure of the outlet temperature sensor	Temperature sensor open or short circuit	Unit stops, alarm	Y	Check the sensor (replace sensor)
9	Failure of the sensor at the output of the compressor	Temperature sensor open or short circuit	Unit stops, alarm	Y	Check the sensor (replace sensor)
E	Power supply wrong	Wrong connection or no connection	Unit stops, alarm	Y	Check the connection (follow the Connection Table)

\* Water tube for outlet of the heat exchanger.

## 6. Connection

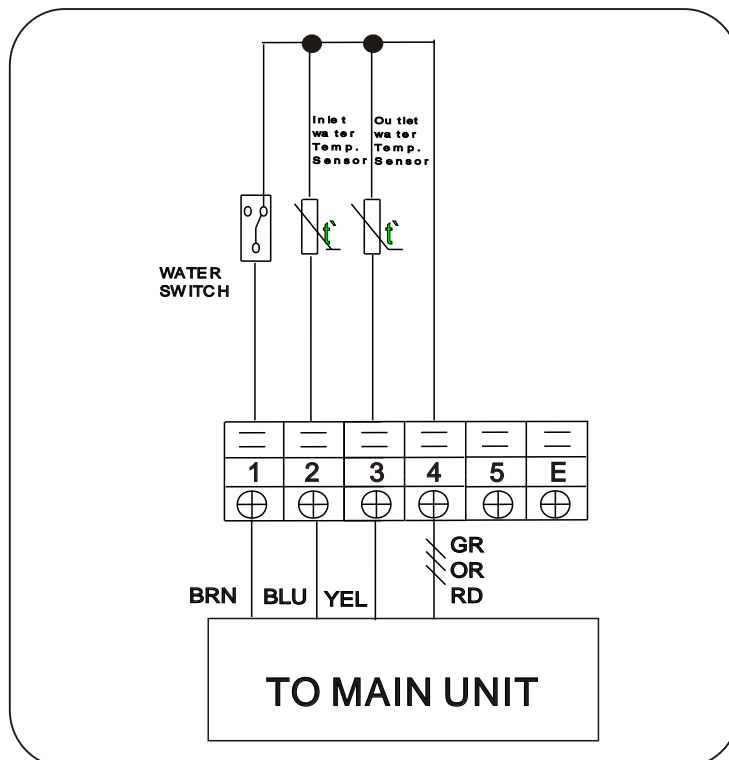
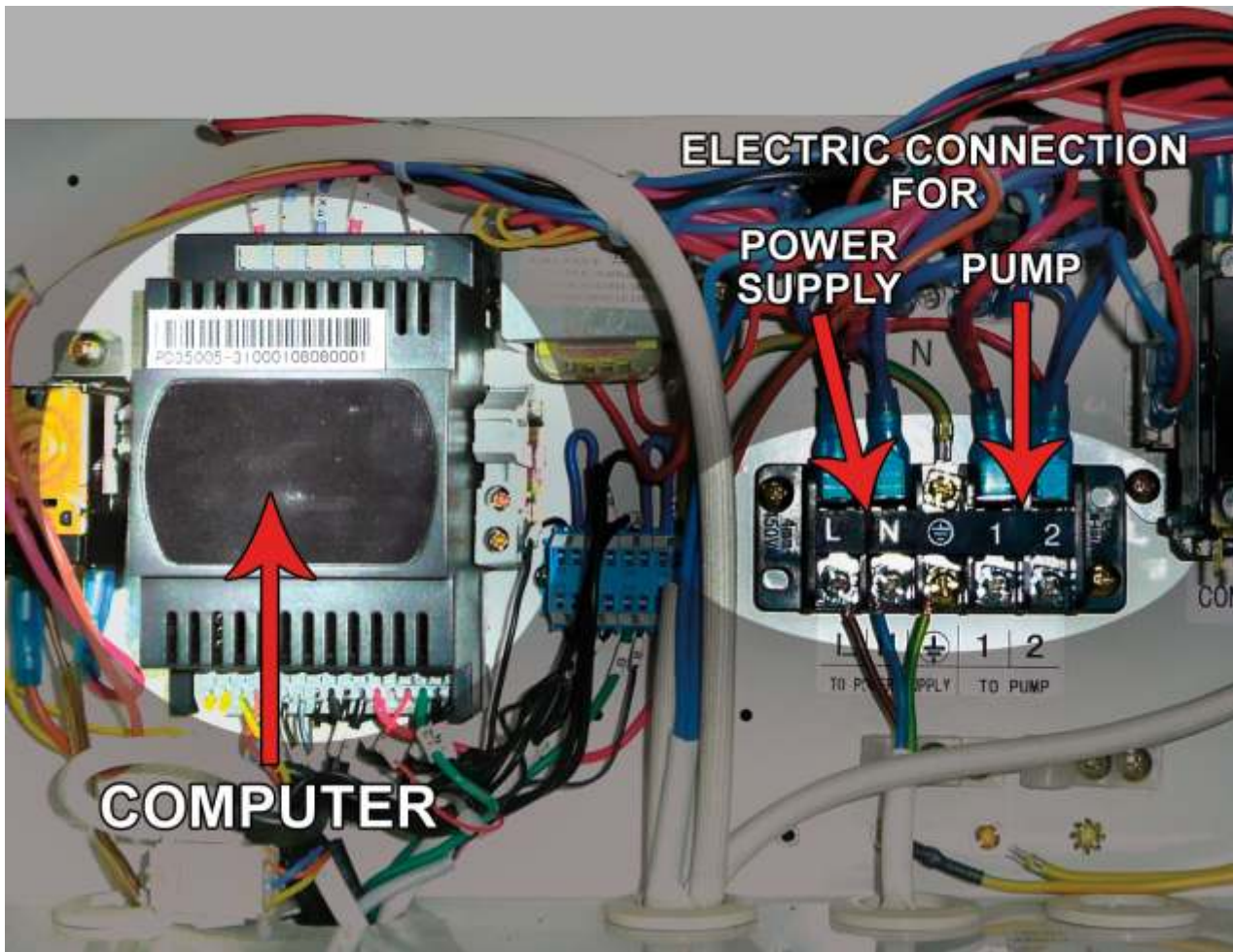

## 7. Exploded View and Spare Parts PG10C, PG15C

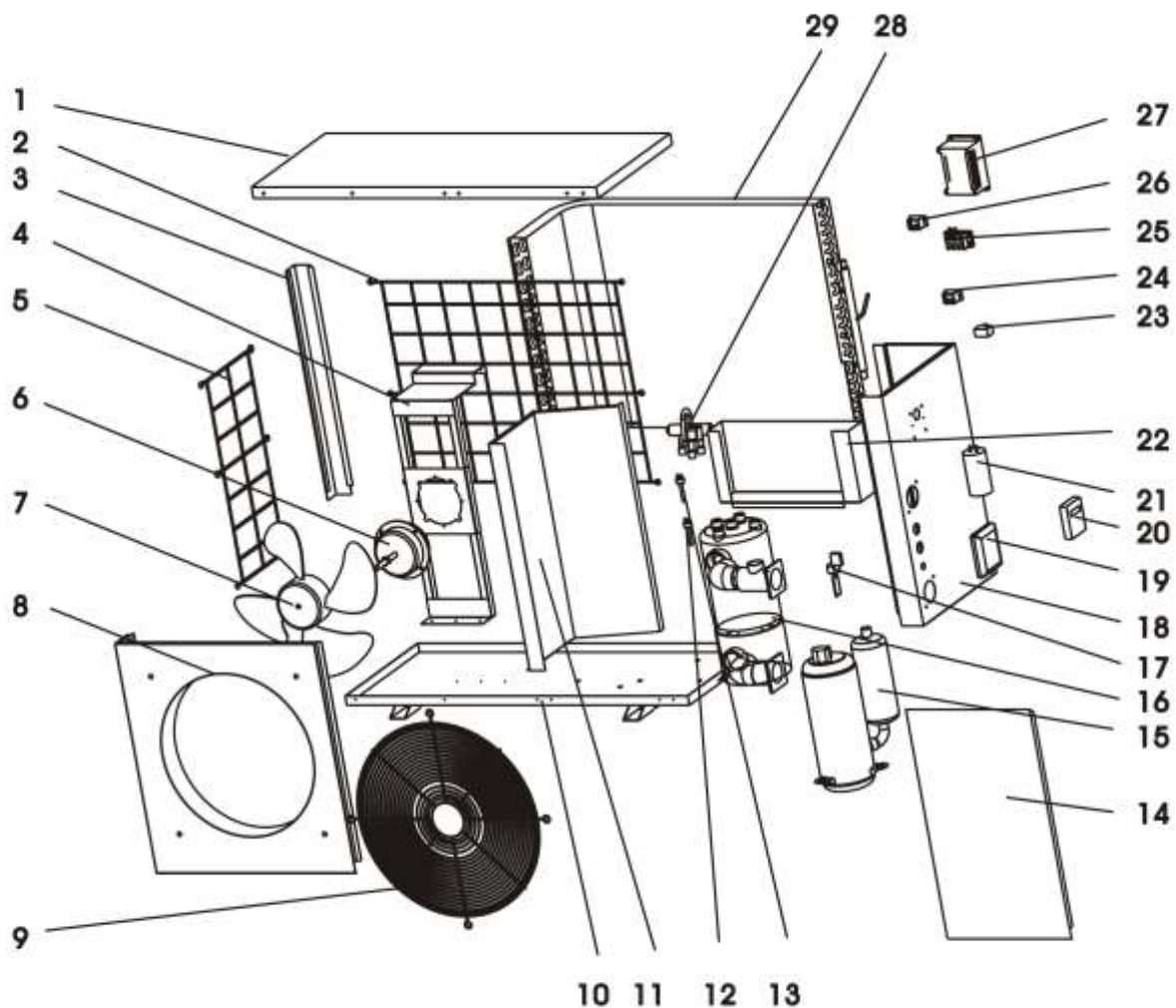

Pos.	Part Name	Pos.	Part Name
01	Top cover	16	Heat exchanger
02	Back web	17	Water flow switch
03	Back holder	18	Right panel
04	Motor bracket	19	Box for wire controller
05	Left web	20	LED-wire controller
06	Fan motor	21	Comp. capacitance
07	Axial blower fan	22	Controlling box
08	Front panel	23	Motor capacitance
09	Fan protection web	24	Relay
10	Bottom plate	25	Terminal 2
11	Middle plate	26	Relay
12	Pressure switch (Low)	27	Main controller
13	Pressure switch (Mid)	28	4 way valvel
14	Front-right panel	29	Down condenser
15	Compressor		

## 7. Exploded View and Spare Parts PG20C

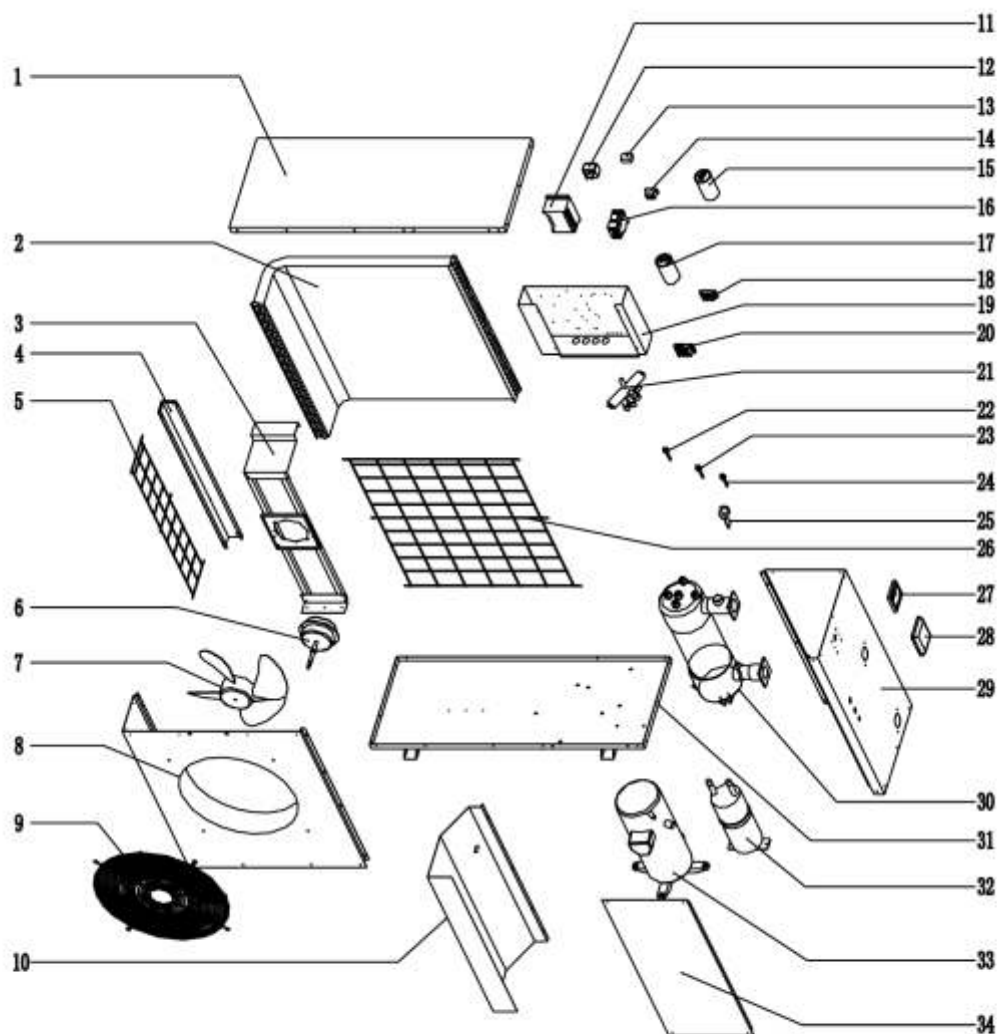

Pos.	Part name	Pos.	Part name
01	Top cover	18	Terminal 6
02	Condenser	19	Controlling box
03	Motor bracket	20	Terminal
04	Back holder	21	4-way valve
05	Left web	22	Pressure switch (mid)
06	Fan motor	23	Pressure switch (low)
07	Axis blower fan	24	Pressure switch (high)
08	Front panel	25	Water flow switch
09	Fan protection web	26	Back web
10	Middle plate	27	LED-wire controller
11	Controlling box	28	Box for wire controller
12	comp. starting relay	29	Right panel
13	Motor capacitance	30	Heat exchanger
14	Relay	31	Bottom plate
15	Comp capacitance (running)	32	
16	AC contactor	33	Compressor
17	Comp. capacitance (starting)	34	Front-right panel

## 7. Exploded View and Spare Parts PG15S, (PG10S)

Main unit

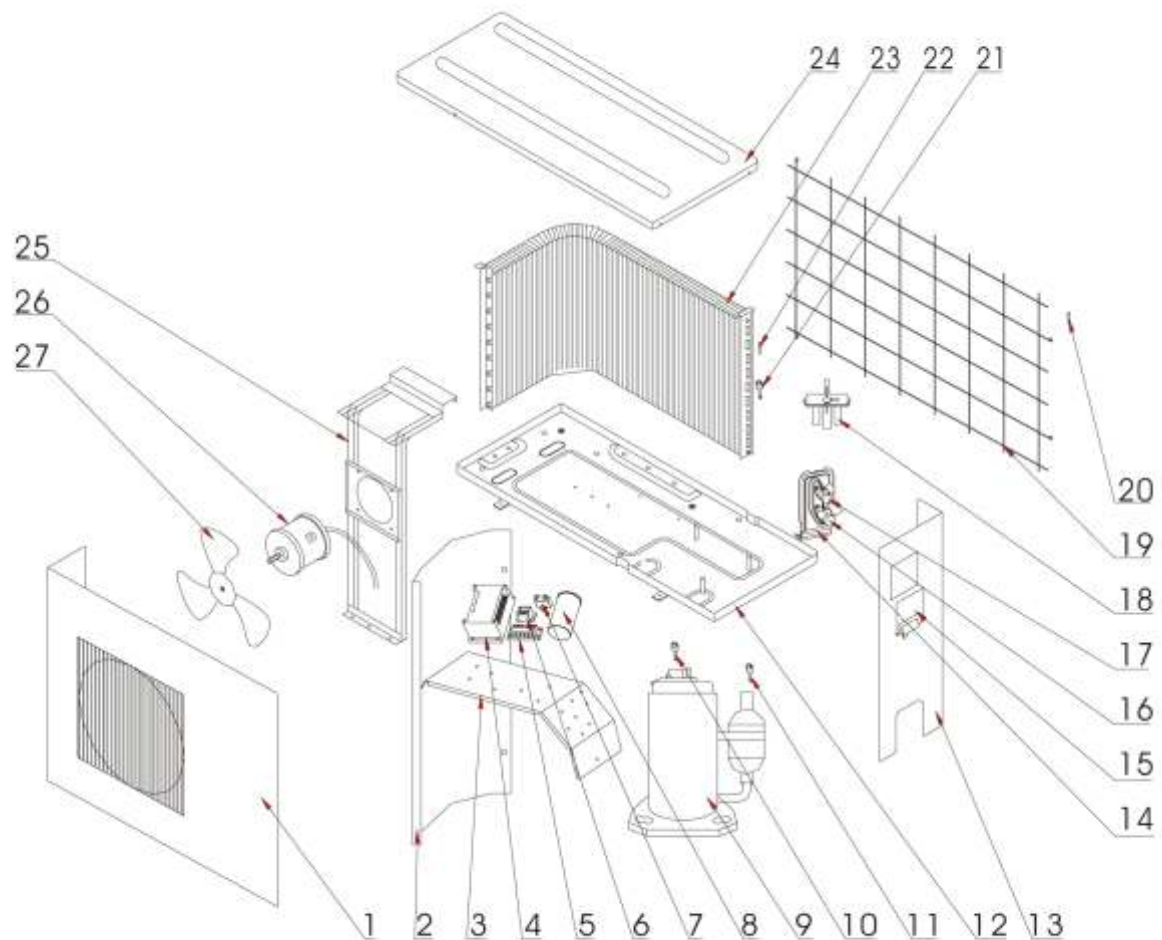

Pos.	Part name	Pos.	Part name
01	Front panel	15	Right panel
02	Middle panel	16	Electrical cover
03	Electrical support	17	3/8 " valve
04	Main controller	18	5/8 " valve
05	Relay	19	4-way valve
06	Terminal	20	Back web
07	Relay	21	Temperature sensor
08	Compressor capacitor	22	Overload switch
09	Fan-motor capacitor	23	Temperature sensor
10	Terminal	24	Condenser
11	Compressor	25	Top cover
12	High pressure switch	26	Fan motor bracket
13	Low pressure switch	27	Fan motor
14	Chassis	28	Fan



## 7. Exploded View and Spare Parts (PG10S), PG15S - Water Unit

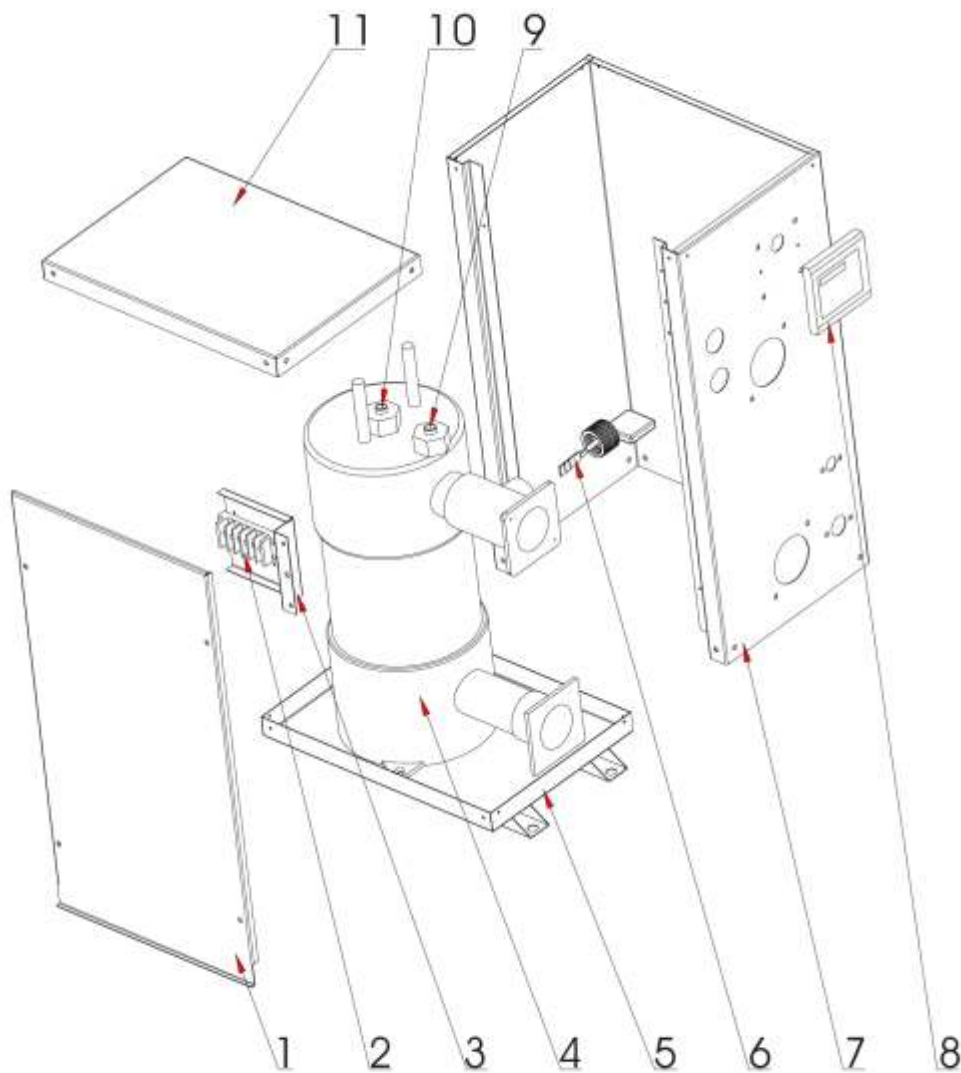

Pos.	Part name	Pos.	Part name
01	Panel	07	Panel
02	Terminal	08	LED wire controller
03	Electrical box bracket	09	Water outlet temp. sensor
04	Titanium heat exchanger	10	Water inlet temp. sensor
05	Chassis	11	Top cover
06	Water flow switch		

## 7.1 Unit Specifications - Dimensions - Compact Models

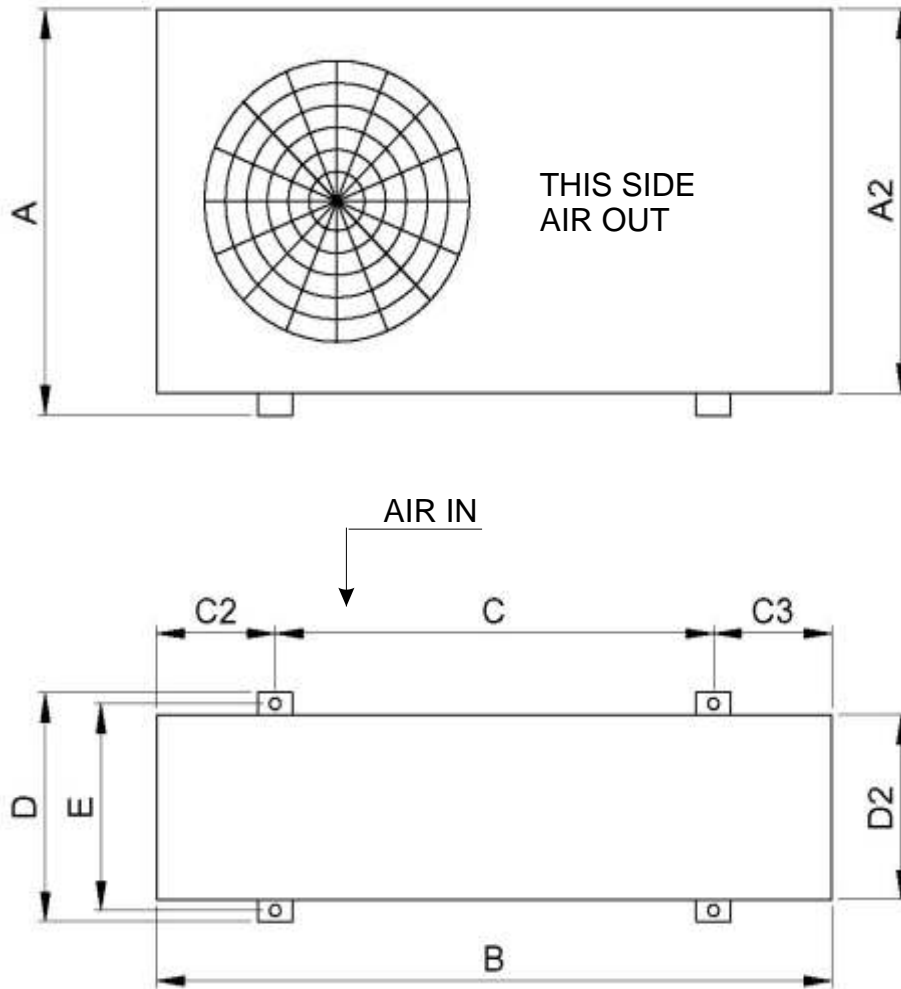

Unit Specifications - Dimensions [mm]

Type	PG15C	PG20C
Dimensions		
A	650	850
A2	620	820
B	1000	1110
C	700	720
C2	150	195
C3	150	195
D	420	470
D2	390	430
E	400	450

## 7.2 Unit Specifications - Dimensions - Split Models

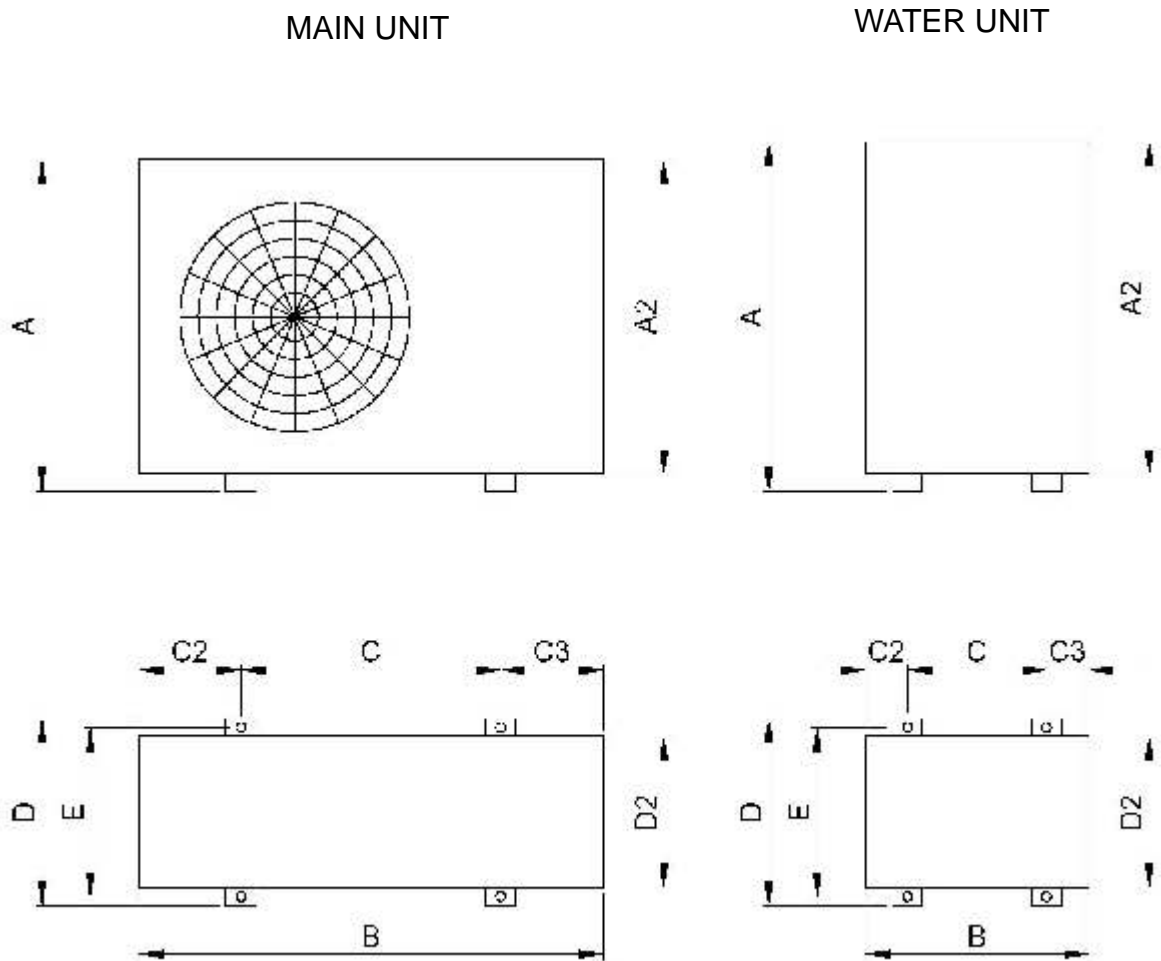

Unit Specifications - Dimensions [mm]

Dimensions	Type	PG15S	
		Main unit	Water unit
A		705	550
A2		690	530
B		890	368
C		510	125
C2		155	55
C3		155	55
D		380	232
D2		310	235
E		350	215

## 8 Our Production-Delivery Program

Input	Recomended Model	Heated May to Sept. Pool size [m2/ft2]	Heated March to Nov. Pool size [m2/ft2]
10 kW	PG10C	30/300	20/200
15 kW	PG15C	50/500	30/300
20 kW	PG20C	80/800	50/500
30 kW	PG15C + PG15C	100/1000	80/800
35 kW	PG20C + PG15C	130/1300	100/1000
40 kW	PG20C + PG20C	160/1600	130/1300